



Exploring

AI, ML, DL

Innovations for a better world



Hello!

I am **Ayon Roy**

Executive Data Scientist @ NielsenIQ

Helped **3900+** students kickstart their ML Journey

Mentored/Judged **100+** Hackathons

Delivered **65+** Technical Talks

Started **India's 1st** Kaggle Days Meetup Community

Visit - AYONROY.ML

AGENDA (23rd August 2022)

- Introduction to Artificial Intelligence, Machine Learning, Deep Learning
- Introduction to Neural Networks, Deep Neural Networks, Recurrent Neural Networks, Convolutional Neural Networks
- Definition & Applications of commonly used terminologies while developing AI Based Models
- Question & Answer Session

Graphical Representation of what we will discuss today

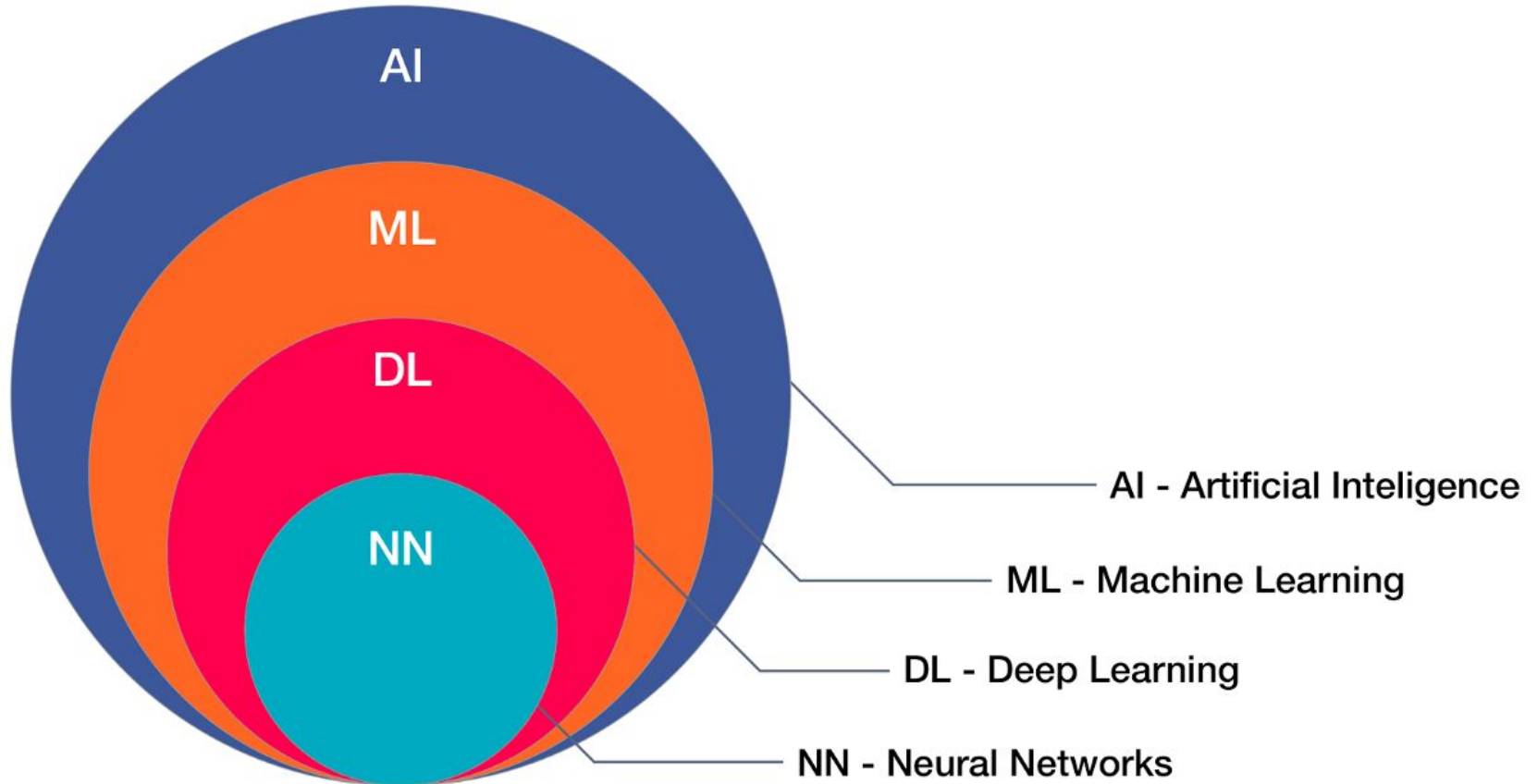

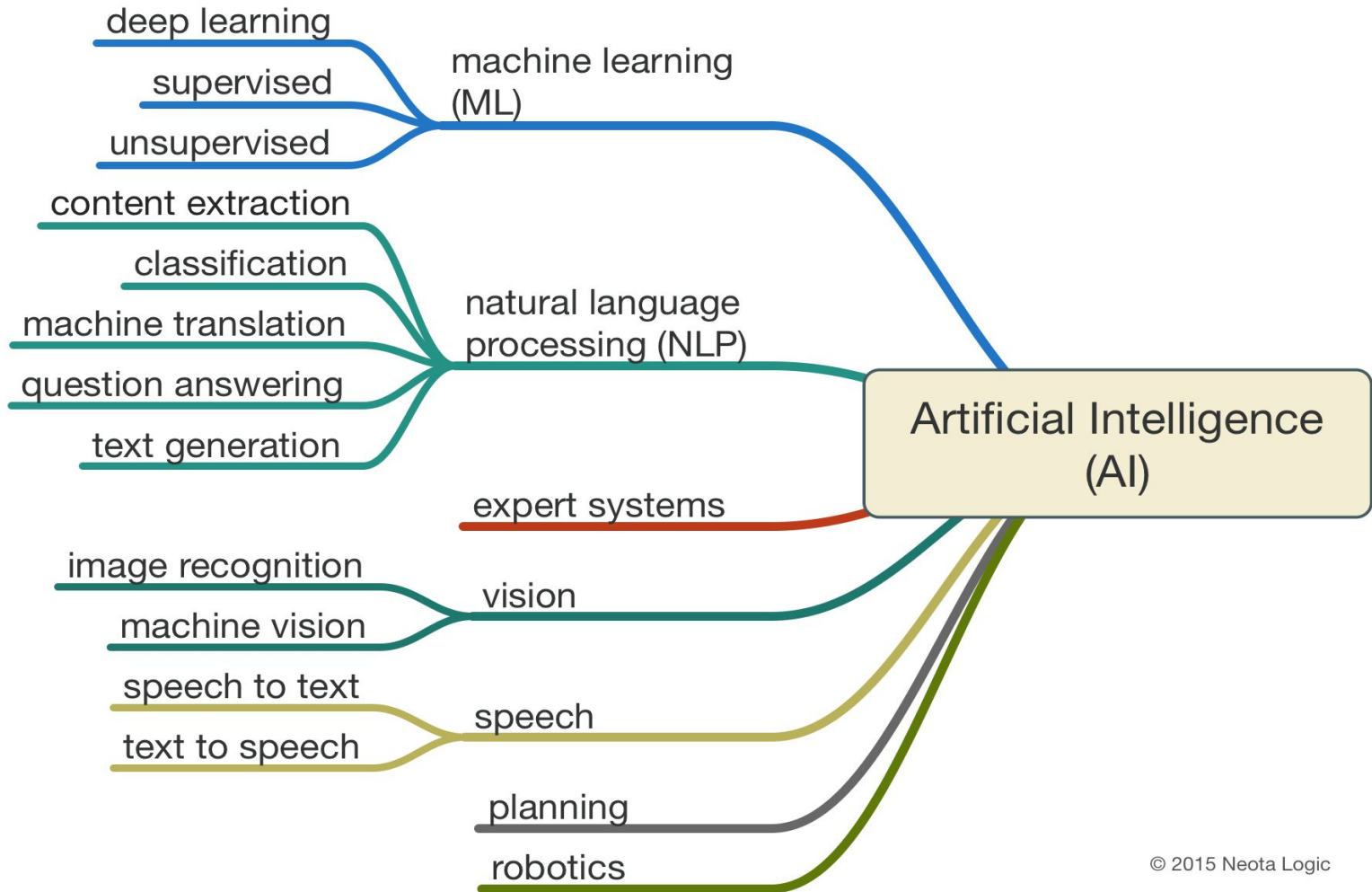

But why AI, ML, DL now ?

1. The sharp decrease in costs associated with data storage and processing.
2. The advent of the Internet economy and the explosion in mobile apps.
3. The abundance of open-source tools.
4. The development of a wealth of innovative ML and DL algorithms.
5. Availability of GPUs etc.

So, what is AI, ML, DL ?

Artificial Intelligence

A technique for incorporating human intelligence to machine

Machine Learning

ML is a subset of AI that provides systems the ability to automatically learn and improve from experience without being explicitly programmed. ML is about learn from past to predict the future.

Deep Learning

DL is a subset of ML where artificial neural networks, algorithms inspired by the human brain, learn from large amounts of data.

Defining Artificial Intelligence

AI is the *branch of computer science* tasked with the design and construction of **intelligent agents**.

An intelligent agent is in turn any agent that is (mostly):

- **autonomous** (able to perform tasks without *constant* guidance)
- **adaptable** (able to improve performance by learning from experience)
- **able to sense** and efficiently abstract features of its environment (perception)
- **able to act “rationally”** i.e it is moving towards maximizing a quantitative and objective utility function or performance measure.

Applications of Artificial Intelligence

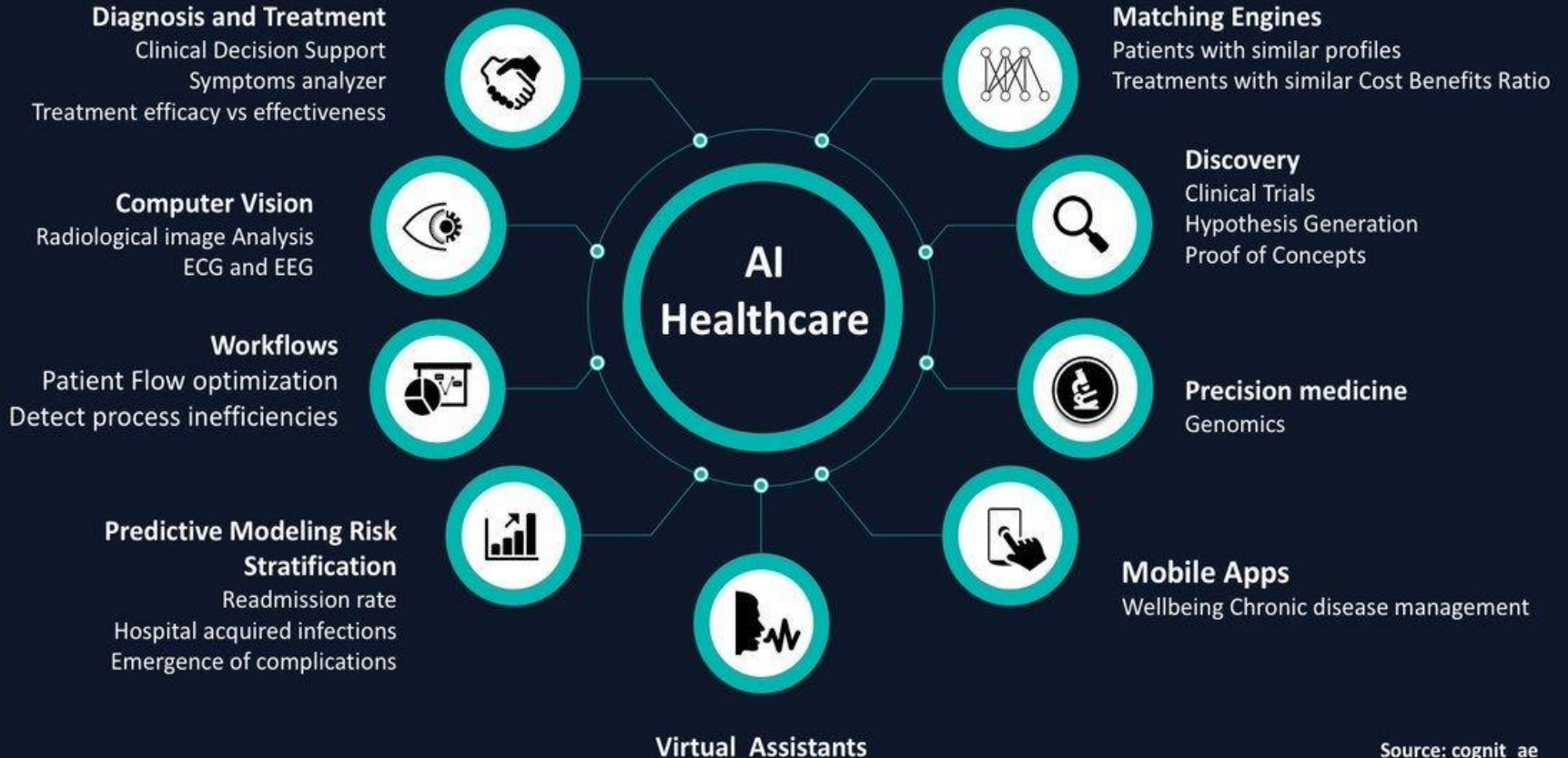

Defining Machine Learning











An Approach to Achieve Artificial Intelligence

Subfield of AI that aims to teach computers the ability to do tasks with data, without explicit programming.

We can get AI without using machine learning, but this would require building millions of lines of codes with complex rules and decision-trees.

So instead of hard-coding software routines with specific instructions to accomplish a particular task, machine learning is a way of “training” an algorithm so that it can learn how.

Applications of Machine Learning

APPLICATION	POTENTIAL ANNUAL VALUE BY 2026	KEY DRIVERS FOR ADOPTION
Robot-assisted surgery	 \$40B	Technological advances in robotic solutions for more types of surgery
Virtual nursing assistants	 20	Increasing pressure caused by medical labor shortage
Administrative workflow	 18	Easier integration with existing technology infrastructure
Fraud detection	 17	Need to address increasingly complex service and payment fraud attempts
Dosage error reduction	 16	Prevalence of medical errors, which leads to tangible penalties
Connected machines	 14	Proliferation of connected machines/devices
Clinical trial participation	 13	Patent cliff; plethora of data; outcomes-driven approach
Preliminary diagnosis	 5	Interoperability/data architecture to enhance accuracy
Automated image diagnosis	 3	Storage capacity; greater trust in AI technology
Cybersecurity	 2	Increase in breaches; pressure to protect health data

Defining Deep Learning

A Technique for Implementing Machine Learning

Subfield of ML that uses specialized techniques involving multi-layer artificial neural networks.

In ML, data mostly passes through linear transformational algorithms to produce output. But in DL, data goes through multiple number of non-linear transformational algorithms like matrix transformation to obtain an output.

Other techniques to implement ML include decision tree learning, inductive logic programming, clustering, reinforcement learning, and Bayesian networks etc..

Applications of Deep Learning

Pharma's AlphaGo Moment: For the First Time AI Has Designed and Validated a New Drug Candidate in Days

Published on September 3, 2019

moment for Pharma. Insilico Medicine used a generative approach combined with deep reinforcement learning (the form of AI that was used in AlphaGo) to design and validate a new drug candidate end-to-end in 45 days. This is 15x faster than Pharma companies. The experimental validation confirms the ability of AI to accelerate drug discovery.

Limitations of AI / ML / DL

The human mind is subtle and extraordinary. You cannot tell a robot to be **creative**.

The main limitation is that the agents are typically only able to optimize their decisions and actions to achieve a singular goal.

Eg: A computer vision system that is able to detect melanoma from a skin photograph can be called intelligent but it is not capable of performing any other task that an intelligent person would do.

Some Common Deep Learning Libraries

- Theano
- Tensorflow
- Keras
- PyTorch

And Many more



Neural Networks

What are Neural Networks ?

Computer System inspired by biological networks of neurons that learn progressively i.e which improves performance to do tasks; by considering examples generally without task specific programming.

Why Neural Networks ?

Neural Networks learn by example. So now computers can do things what we don't exactly know how to do.

Applications of Neural Networks

Speech Recognition , Character Recognition, Signature Verification, Face Recognition etc.

Single Perceptron

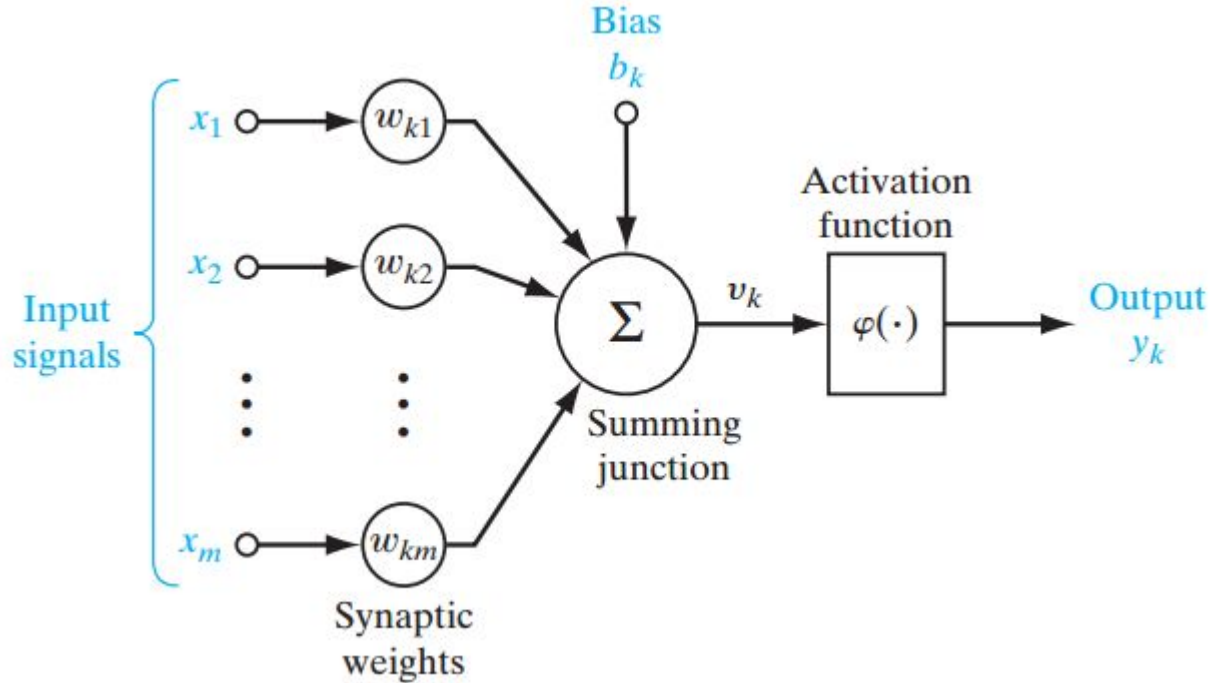

Many such Perceptrons combine together to form a Neural Network

Working of a Neural Network

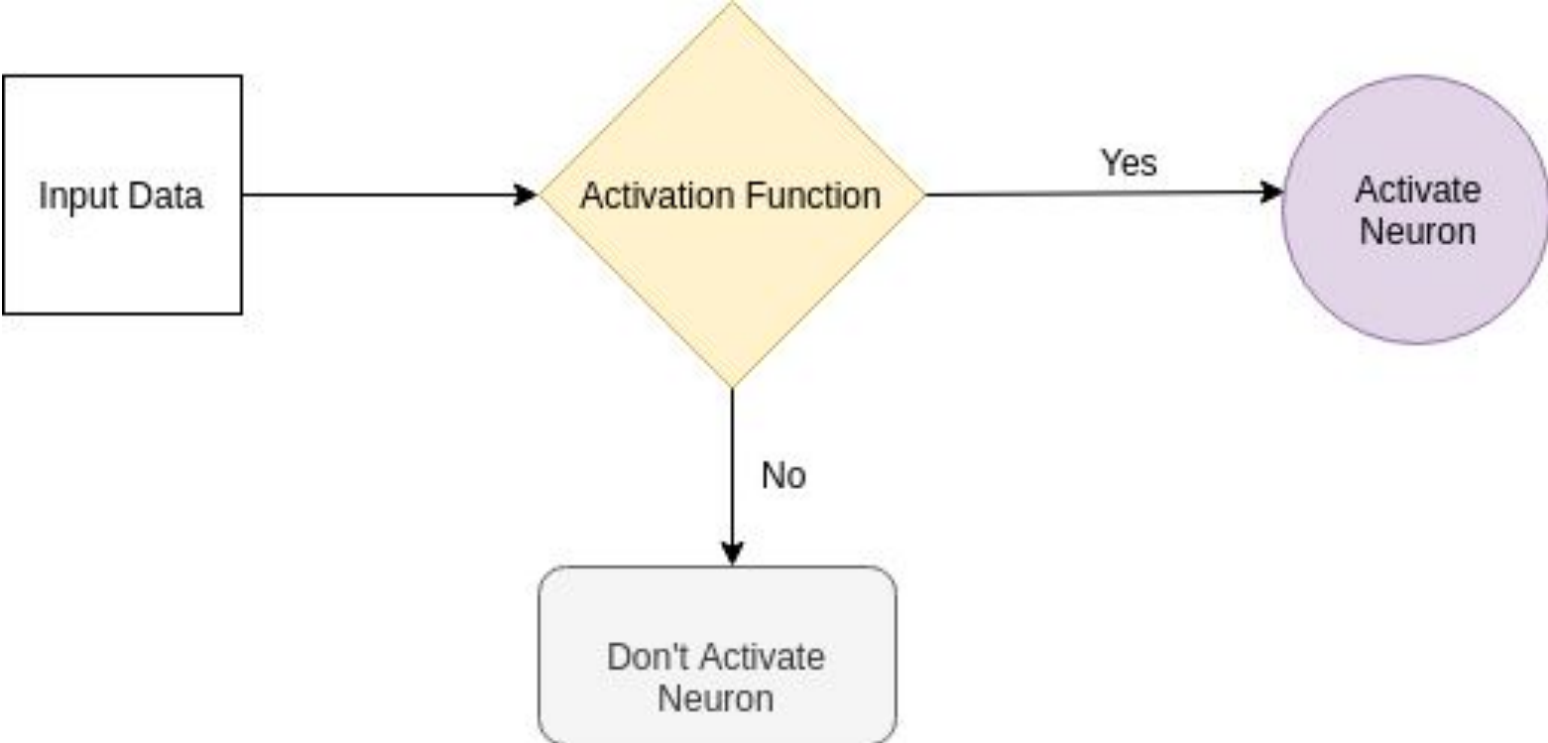

Basic Terminologies

One **epoch** = one forward pass and one backward pass of *all* the training examples

Batch size = the number of training examples in one forward/backward pass. The higher the batch size, the more memory space you'll need.

No. of **iterations** = number of batches needed to complete one epoch

Let's say we have 2000 training examples that we are going to use .

We can divide the dataset of 2000 examples into batches of 500 then it will take 4 iterations to complete 1 epoch.

Where Batch Size is 500 and Iterations is 4, for 1 complete epoch.

Loss Function

Method of evaluating how well your algorithm models your dataset. If the predictions are totally off, it will output a higher number. If they're pretty good, it'll output a lower number. As you change pieces of your algorithm to try and improve your model, your loss function will tell you if you're getting anywhere.

Optimizers

During the training process, we change the parameters (weights) of our model to minimize the loss function, and make our predictions better. But how to do that? Optimizers tie together the loss function and model parameters to shape and mould the model into its most accurate possible form.

The loss function is the guide to the terrain, telling the optimizer when it's moving in the right or wrong direction.

Learning Rate : The learning rate is a parameter that determines how much an updating step influences the current value of the weights. When training a neural network, if the learning rate is :

- **Too small** a learning rate and your neural network may not learn at all
- **Too large** a learning rate and you may overshoot areas of low loss (or even overfit from the start of training)

Momentum : It is a value between 0 and 1 that increases the size of the steps taken towards the minimum by trying to jump from a local minima.

- If the momentum term is large then the learning rate should be kept smaller.
- A large value of momentum also means that the convergence will happen fast.
- But if both the momentum and learning rate are kept at large values, then you might skip the minimum with a huge step.
- A small value of momentum cannot reliably avoid local minima, and can also slow down the training of the system.

A right value of momentum can be either learned by hit and trial or through cross-validation.

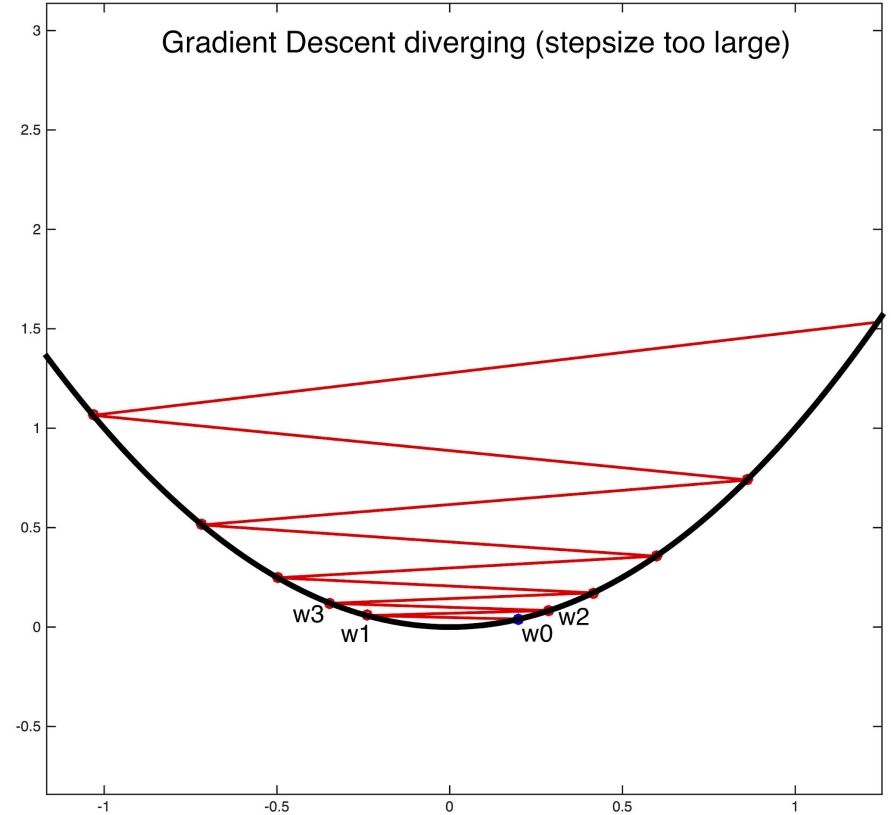
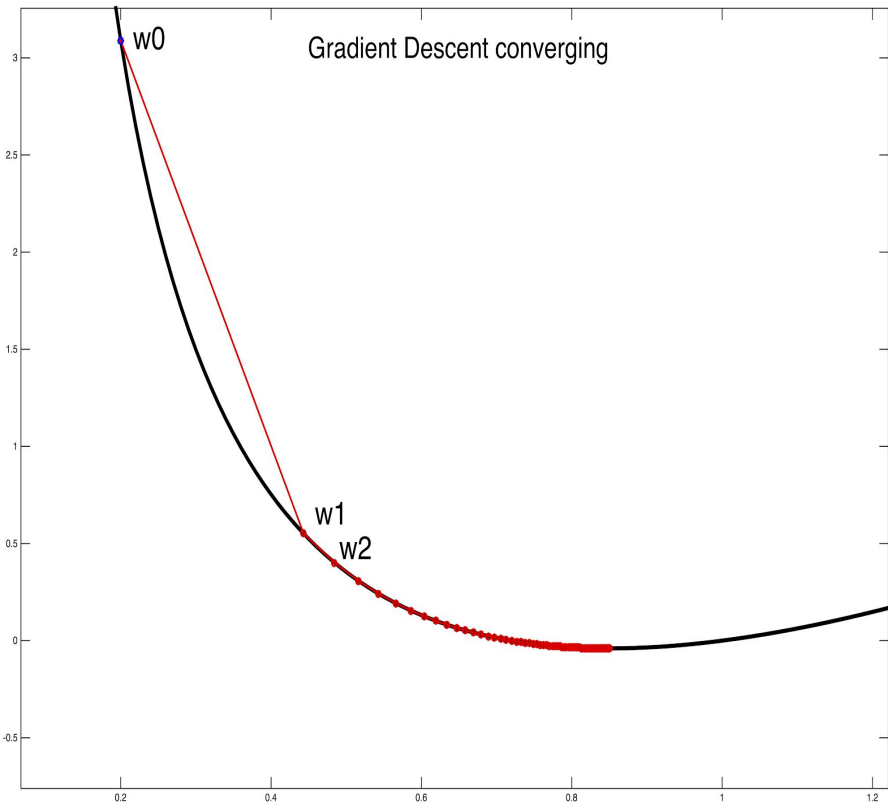

Gradient Descent is a way to find the minimum of a function.

Hyperparameter Tuning

Tuning the hyperparameters effectively can lead to a massive improvement in the overall performance.

Following are a few common hyperparameters we frequently work with in a deep neural network:

- Learning rate – α
- Momentum – β
- Adam's hyperparameter – $\beta_1, \beta_2, \epsilon$
- Number of hidden layers
- Number of hidden units for different layers
- Learning rate decay
- Mini-batch size

Learning rate usually proves to be the most important among the above. This is followed by the number of hidden units, momentum, mini-batch size, the number of hidden layers, and then the learning rate decay.

Hyperparameter tuning relies more on experimental results than theory, and thus the best method to determine the optimal settings is to try many different combinations evaluate the performance of each model.

Activation Functions

Sigmoid

$$\sigma(x) = \frac{1}{1+e^{-x}}$$

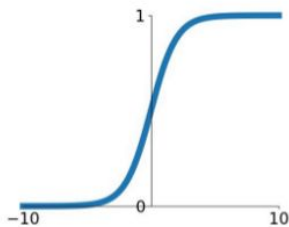

Leaky ReLU

$$\max(0.1x, x)$$

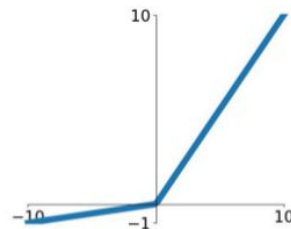

tanh

$$\tanh(x)$$

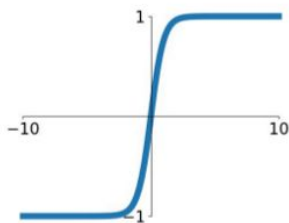

Maxout

$$\max(w_1^T x + b_1, w_2^T x + b_2)$$

ReLU

$$\max(0, x)$$

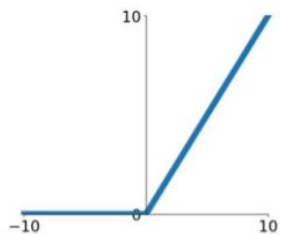

ELU

$$\begin{cases} x & x \geq 0 \\ \alpha(e^x - 1) & x < 0 \end{cases}$$

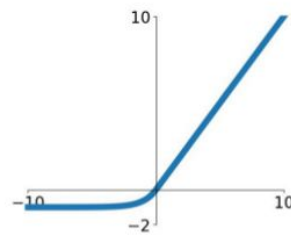

providing lift for
classification and
forecasting models

Deep Neural Networks

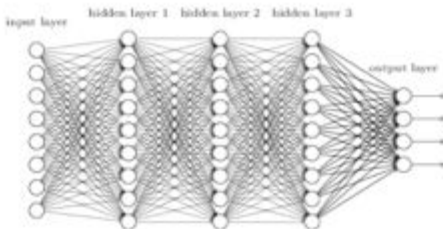

feature extraction
and classification of
images

Convolutional Neural Networks

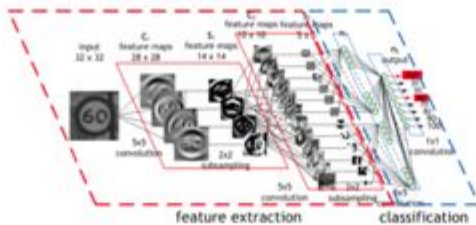

for sequence of events,
language models, time
series, etc.

Recurrent Neural Networks

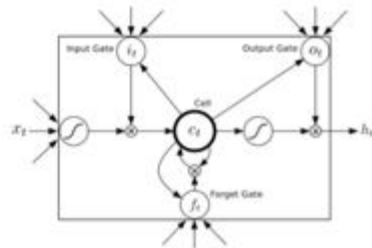

Deep Neural Network

"Non-deep" feedforward neural network

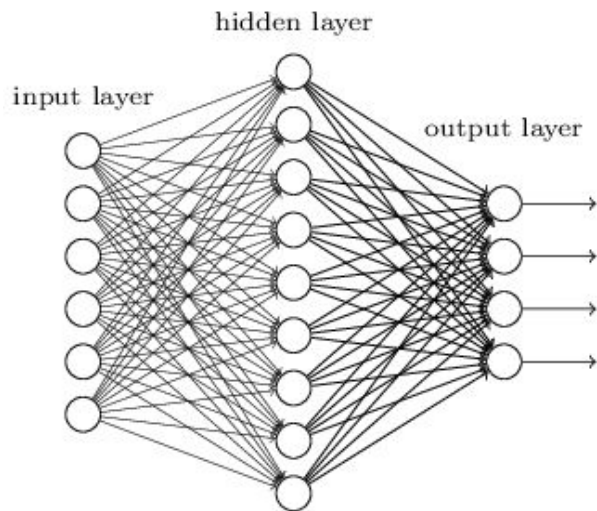

Deep neural network

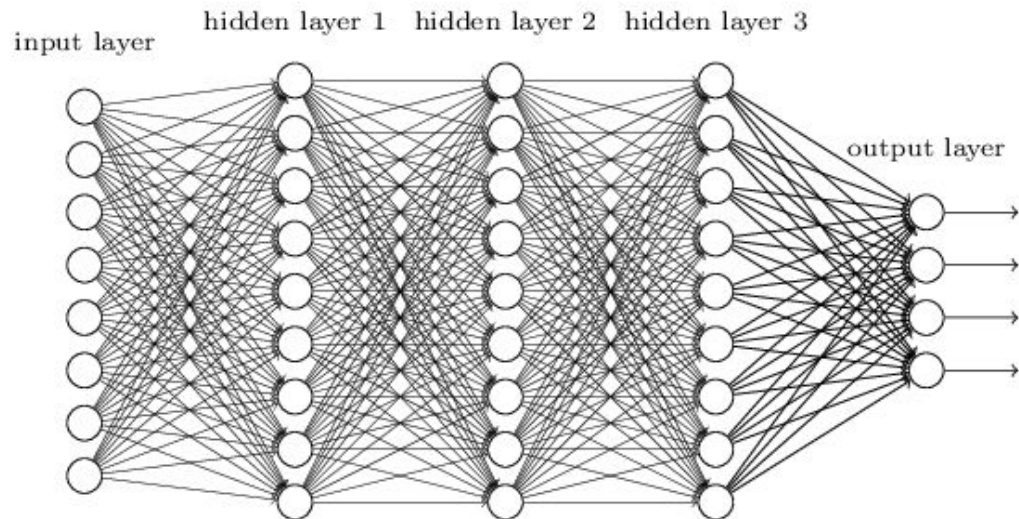

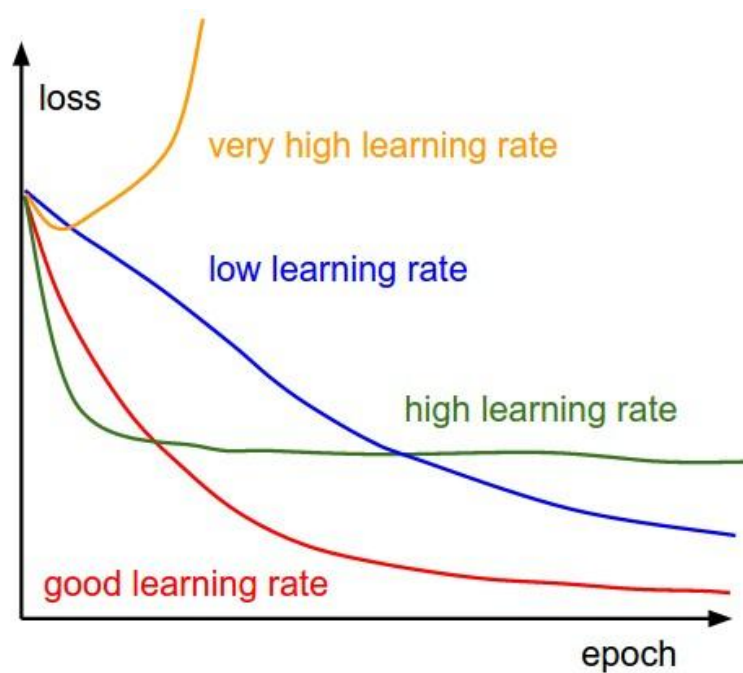
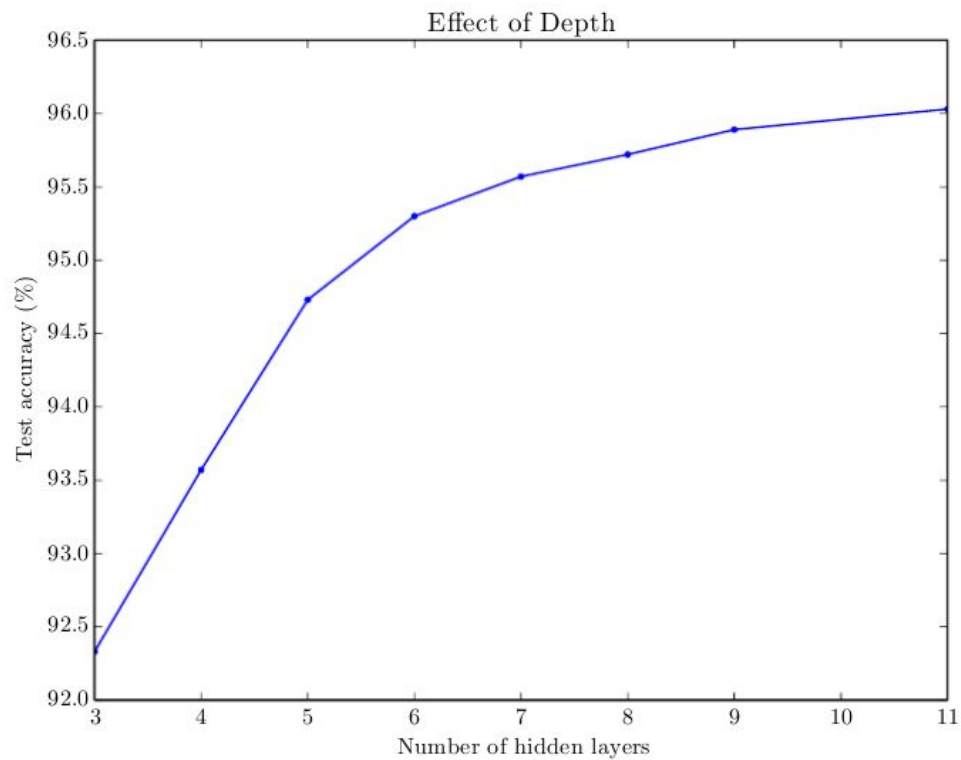

Convolutional Neural Network

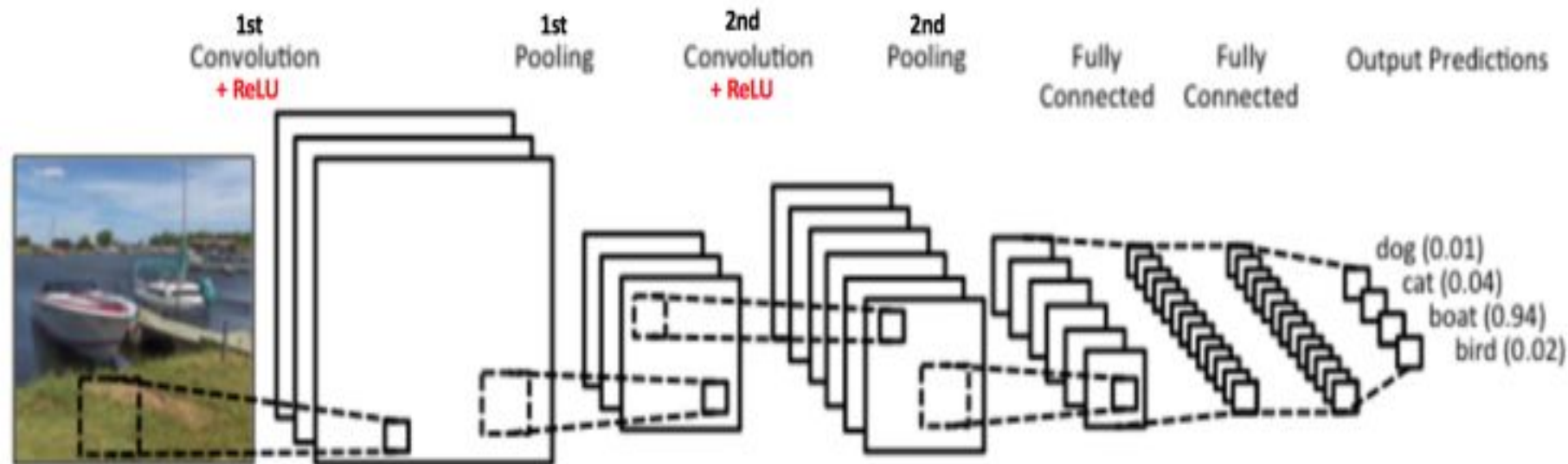

Input -> Conv -> ReLU -> Conv -> ReLU -> Pool -> ReLU -> Conv -> ReLU -> Pool -> Fully Connected

Input Image

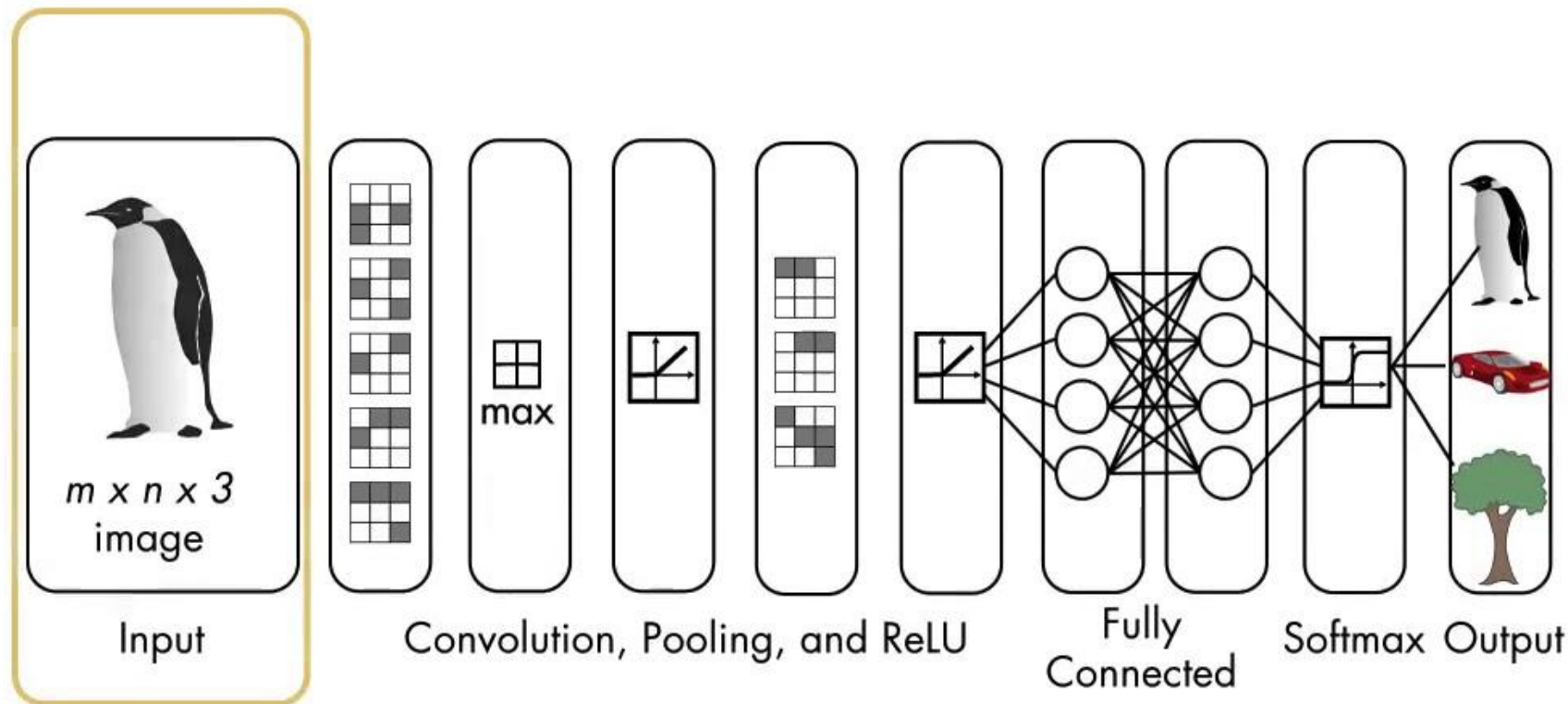

Convolutional Layer

1	1	1	0	0
0	1	1	1	0
0	0	1	1	1
0	0	1	1	0
0	1	1	0	0

Original Image

1	0	1
0	1	0
1	0	1

Feature Matrix

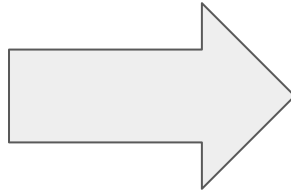

1 _{x2}	1 _{x0}	1 _{x2}	0	0
0 _{x0}	1 _{x1}	1 _{x0}	1	0
0 _{x1}	0 _{x0}	1 _{x1}	1	1
0	0	1	1	0
0	1	1	0	0

Image

4		

Convolved Feature

Pooling Layer

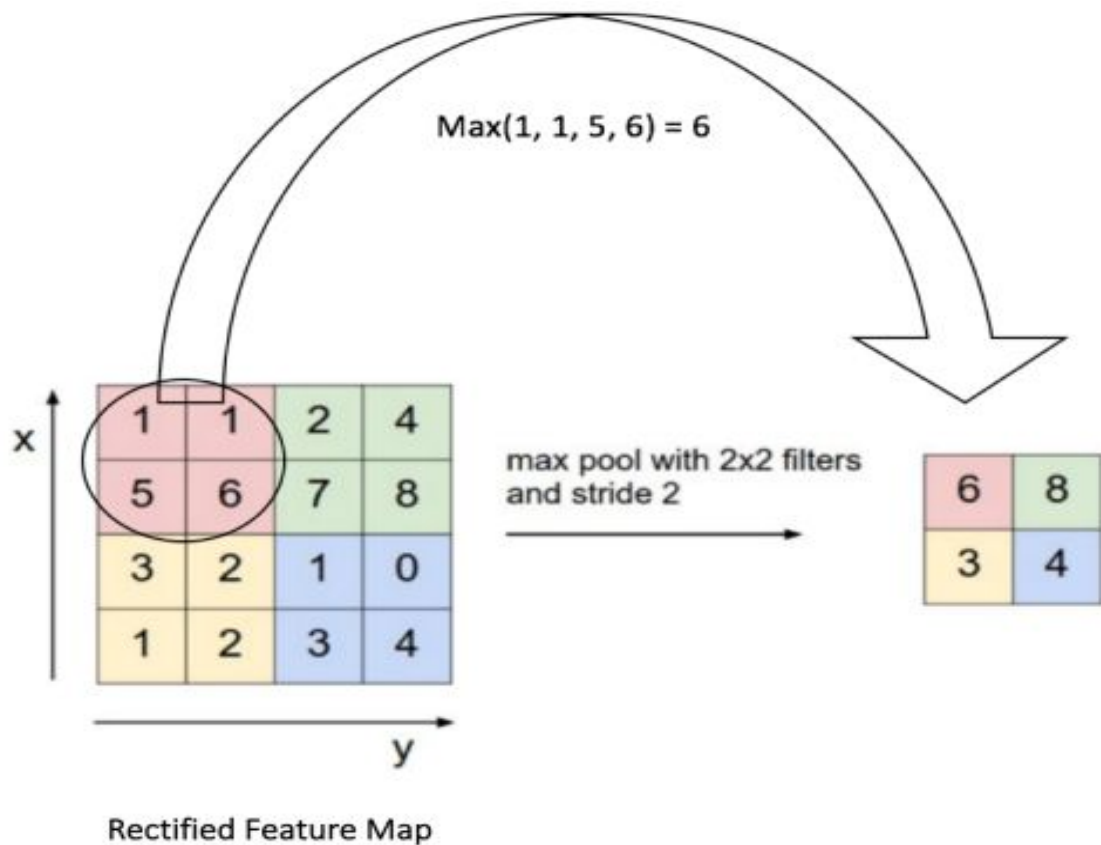

ReLU Layer

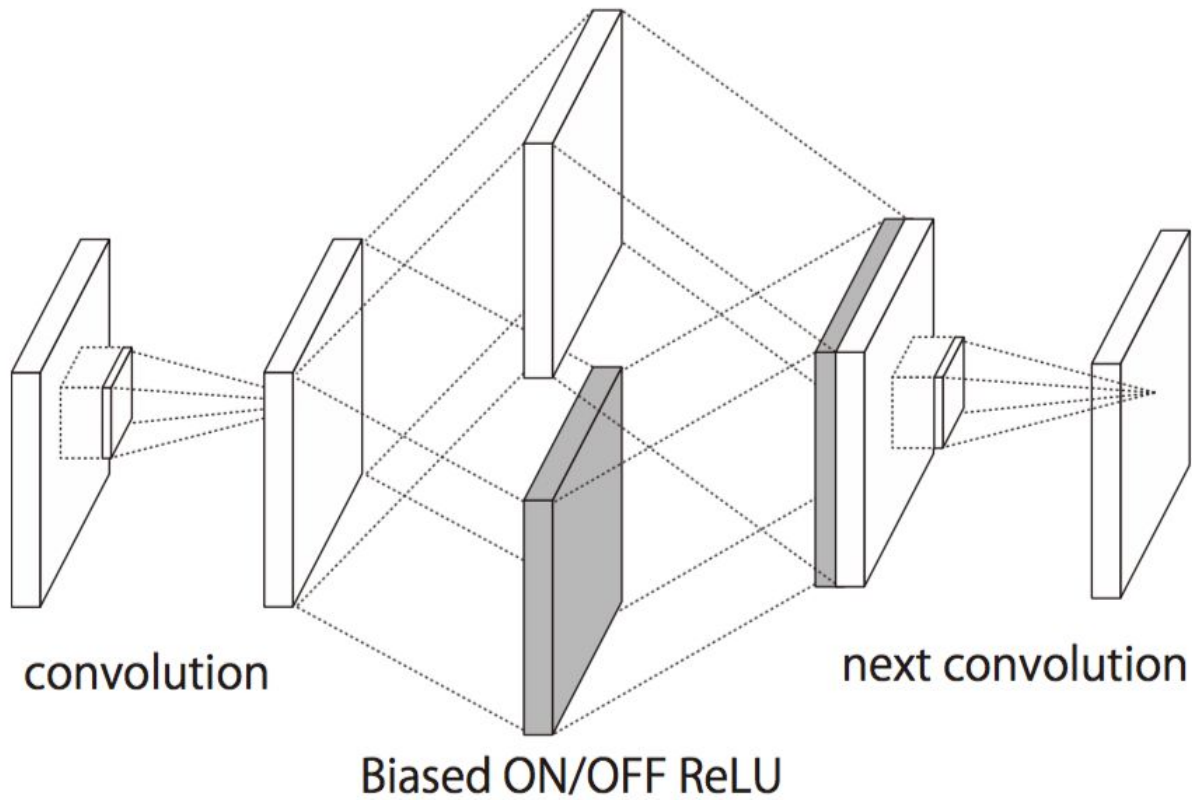

Final Connected Layer

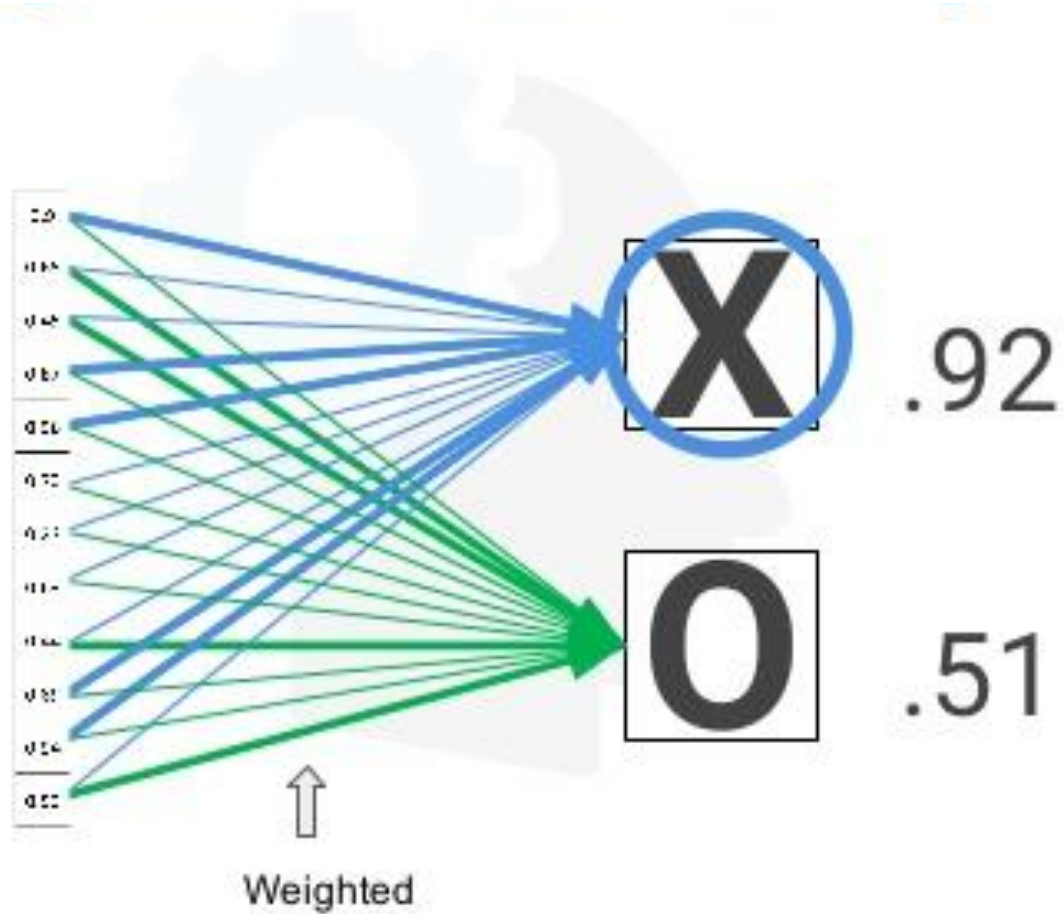

SoftMax Layer & Sigmoid Activation Function

Soft-Max

Used for multi-classification
in logistic regression model.

The probabilities sum will be 1

Used in the different layers of
neural networks.

The high value will have the higher
probability than other values.

Sigmoid

Used for binary classification in
logistic regression model.

The probabilities sum need not be 1

Used as activation function while
building neural networks

The high value will have the high
probability but not the higher

Recurrent Neural Network

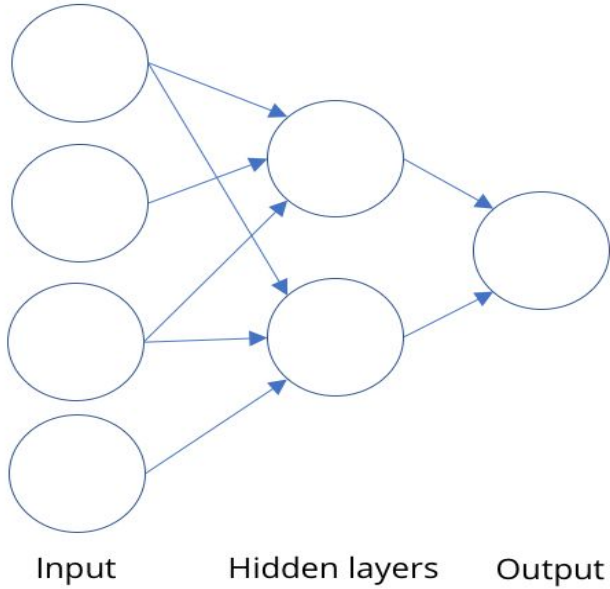

Typical neural network

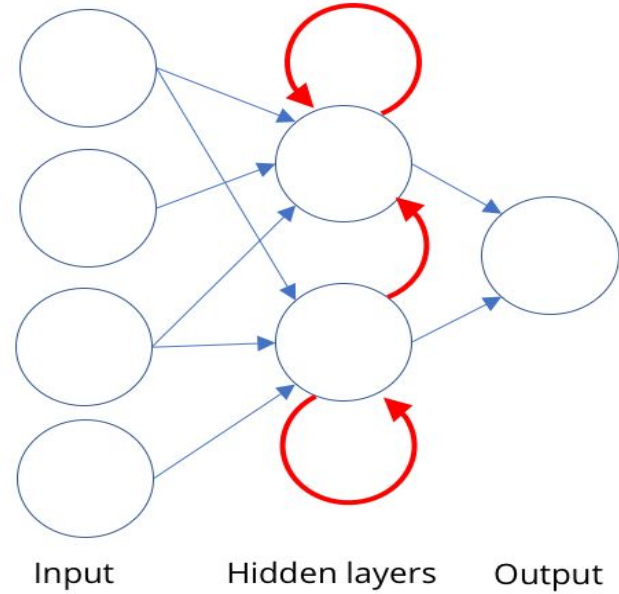

Recurrent neural network

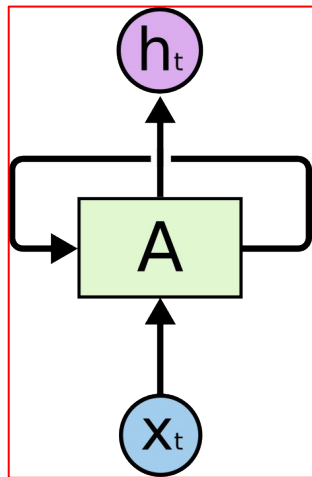

Structure of a RNN

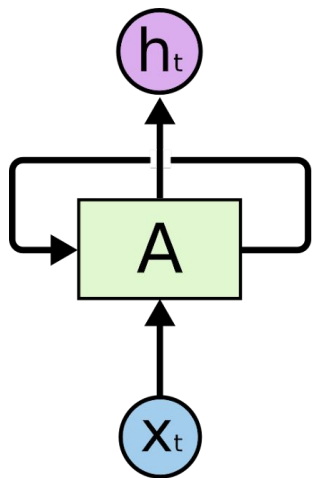

=

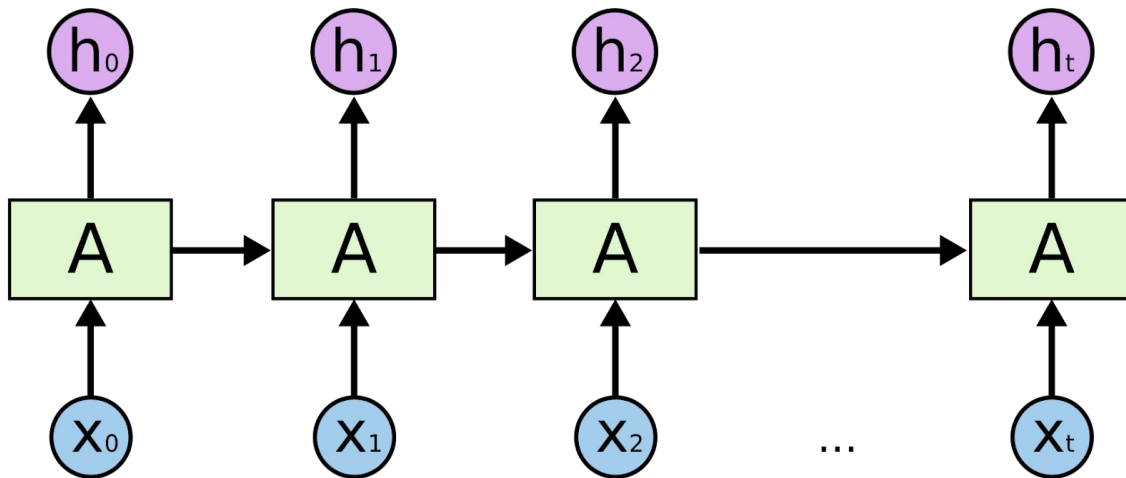

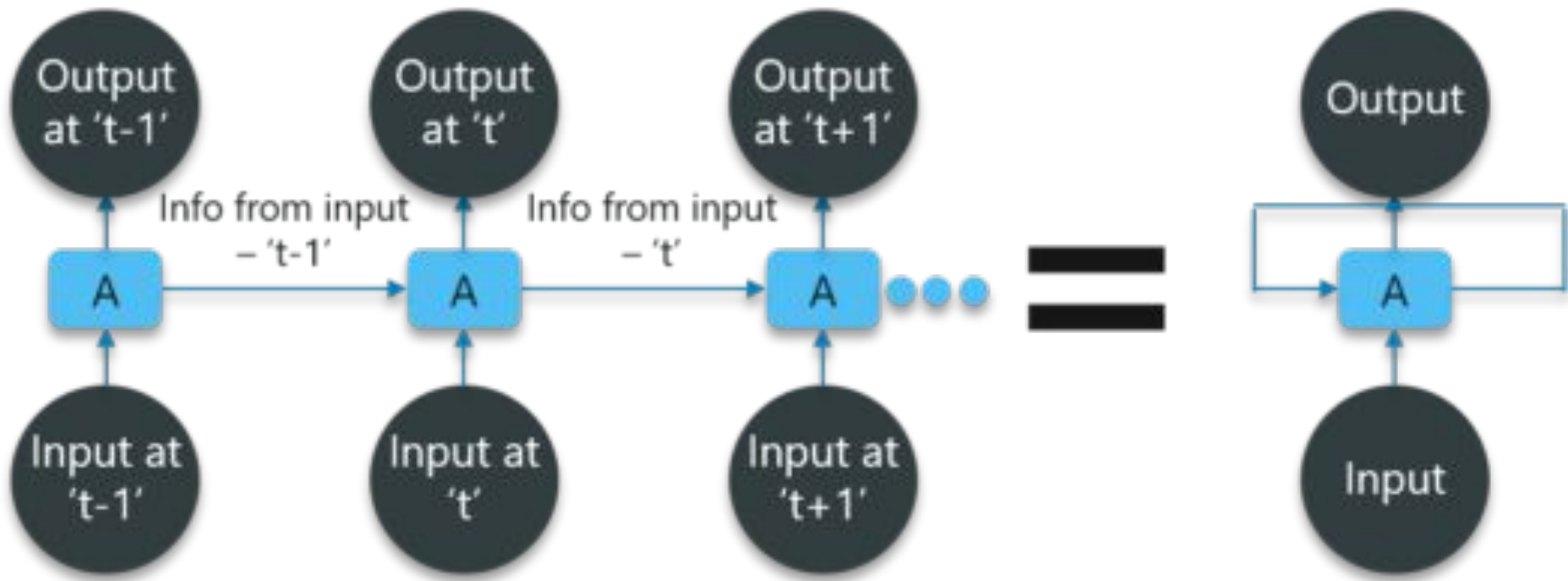

But RNNs uses backpropagation algorithm for every timestamp in order to train the Neural Network. Back propagation has 2 major issues - Vanishing Gradient , Exploding Gradient .

There are concepts like LSTMs etc. to overcome these issues.

GO FOR IT !

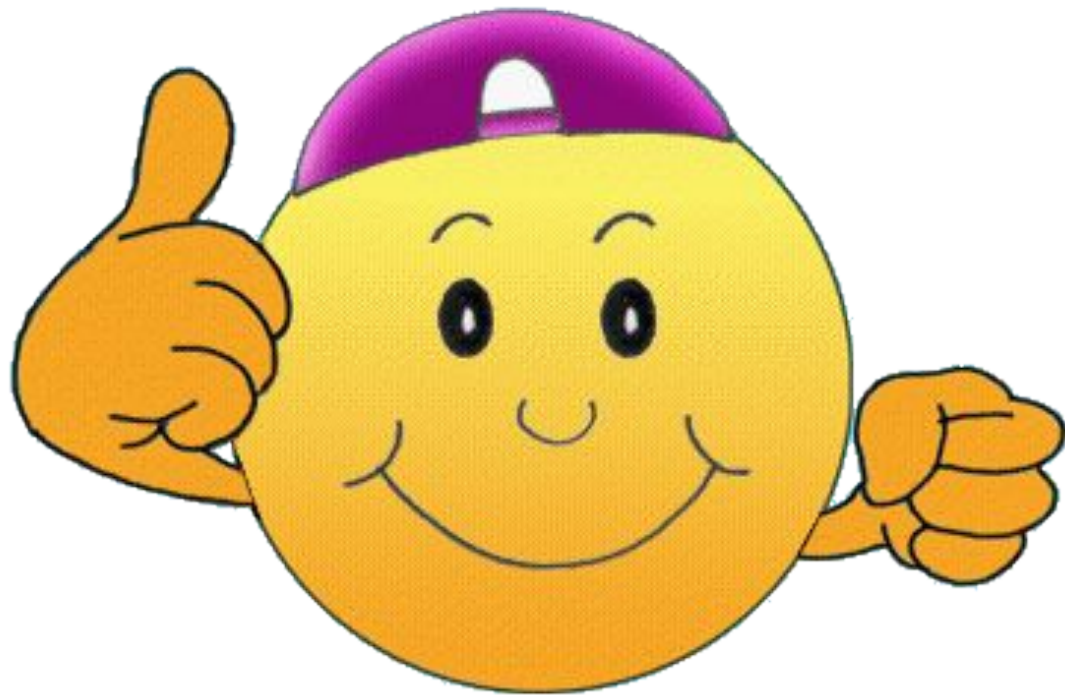

GOOD LUCK !

Let me answer your Questions now.

Finally, it's your time to speak.



Danke Schoen

Questions ? Any Feedbacks ? Did you like the talk?
Tell me about it.

If you think I can help you,
connect with me via

Email : ayon-roy@outlook.com

LinkedIn : <https://www.linkedin.com/in/ayon-roy/>

Website : <https://AYONROY.ML/>